



18-CD34D1-7-EN

INSTALLER'S GUIDE

Upflow/Horizontal — Downflow/Horizontal, Gas-Fired Furnaces, "Fan Assisted Combustion System"

M801P040AU24AA	M801P100BU36AA	M801P060AD24AA	M801P100CD60AA
M801P060AU24AA	M801P100CU48AA	M801P060AD36AA	M801P120DD60AA
M801P060AU36AA	M801P100CU60AA	M801P080BD45AA	M801P140DD60AA
M801P080BU36AA	M801P120DU60AA	M801P100CD48AA	
M801P080BU48AA	M801P140DU60AA		

ALL phases of this installation must comply with NATIONAL, STATE AND LOCAL CODES

IMPORTANT—This Document is customer property and is to remain with this unit. Please return to service information pack upon completion of work.

For VENT SIZING INFORMATION see:

USA —

National Fuel Gas Code ANSI Z223.1/ NFPA 54 (latest version)

CANADA—

Natural Gas Installation Code CAN/ CGA-B149.1 (latest version)

Propane Installation Code CAN/ CGA-B149.2 (latest version)



OPTIONAL ACCESSORIES	
Model Number	Description
BAYBASE205	Downflow subbase for downflow models only
BAYFLTR200	External side filter rack
BAYFLTR203	Filter kit horizontal for 17.5" cabinet
BAYFLTR204	Filter kit horizontal for 21" cabinet
BAYFLTR205	Filter kit horizontal for 24.5" cabinet
BAYFLTR317	Cleanable filter for 17.5" cabinet upflow only
BAYFLTR321	Cleanable filter for 21" cabinet upflow only
BAYFLTR324	Cleanable filter for 24.5" cabinet upflow only
BAYLPKT210B	Propane conversion kit
BAYLPSS210B	LP kit with stainless steel burners
BAYRACK960A	Internals filter rack kit for upflow models
BAYVENT800B	Masonry chimney vent kit for upflow only
KIT09224	Filter clip kit
BAYBRCKFLT10	Downflow bracket kit
FLR01185	Filter for 14-1/2" cabinet downflow only
FLR01186	Filter for 17-1/2", 21", 24-1/2" cabinet downflow only

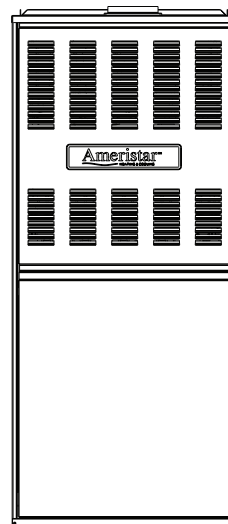

Upflow/Horizontal*

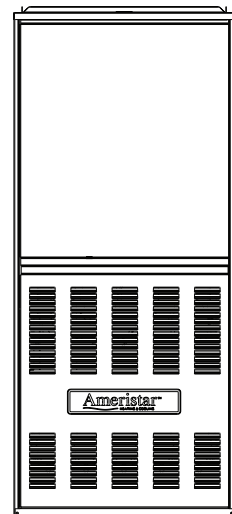

Downflow/Horizontal*

*Horizontal Conversion for these furnaces may be left or right side rotation.

SAFETY SECTION

The following safety practices and precautions must be followed during the installation, servicing, and operation of this furnace.

1. Use only with the type of gas approved for this furnace. Refer to the furnace rating plate.
2. Install this furnace only in a location and position as specified in "Location and Clearances" in this document.
3. Provide adequate combustion and ventilation air to the furnace space as specified in "Air for Combustion and Ventilation" in this document.
4. Combustion products must be discharged outdoors. Connect this furnace to an approved vent system only, as specified in the "Venting" section in this document.
5. Never test for gas leaks with an open flame. Use a commercially available soap solution made specifically for the detection of leaks to check all connections, as specified in "Gas Piping" in this document.
6. Always install the furnace to operate within the furnace's intended temperature-rise range with a duct system which has an external static pressure within the allowable range, as specified on the unit rating plate. Airflow with temperature rise for CFM versus static is shown in this document.
7. When a furnace is installed so that supply ducts carry air circulated by the furnace to areas outside the space containing the furnace, the return air shall also be handled by a duct(s) sealed to the furnace casing and terminating outside the space containing the furnace.
8. A gas-fired furnace for installation in a residential garage must be installed as specified in "Location and Clearances" section in this document.
9. The furnace may be used for temporary heating of buildings or structures under construction only when the following conditions have been met:
 - a. The furnace venting system must be complete and installed per manufacturer's instructions.
 - b. The furnace is controlled only by a room thermostat (no field jumpers).
 - c. The furnace return air duct must be complete and sealed to the furnace and clean air filters are in place.
 - d. The furnace input rate and temperature rise must be verified to be within nameplate marking.
 - e. 100% of the furnace combustion air requirement must come from outside the structure.
 - f. The furnace return air temperature range is between 55 and 80 degrees Fahrenheit.
 - g. Clean the furnace, duct work, and components upon substantial completion of the construction process, and verify furnace operating conditions including ignition, input rate, temperature rise and venting, according to the manufacturer's instructions.

10. This product must be gas piped by a Licensed Plumber or Gas Fitter in the Commonwealth of Massachusetts.

Safety signal words are used to designate a degree or level of seriousness associated with a particular hazard. The signal words for safety markings are **WARNING** and **CAUTION**.

- b. **WARNING** indicates a potentially hazardous situation which, if not avoided, could result in death or serious injury.
- c. **CAUTION** indicates a potentially hazardous situation which, if not avoided, may result in minor or moderate injury. It is also used to alert against unsafe practices and hazards involving only property damage.

GENERAL INSTALLATION INSTRUCTIONS

The manufacturer assumes no responsibility for equipment installed in violation of any code or regulation. It is recommended that Manual J of the Air Conditioning Contractors Association (ACCA) or A.R.I. 230 be followed in estimating heating requirements. When estimating heating requirements for installation at Altitudes above 2000 ft., remember the gas input must be reduced (See GAS INPUT ADJUSTMENT).

Material in this shipment has been inspected at the factory and released to the transportation agency without known damage. Inspect exterior of carton for evidence of rough handling in shipment. Unpack carefully after moving equipment to approximate location. If damage to contents is found, report the damage immediately to the delivering agency.

Codes and local utility requirements governing the installation of gas fired equipment, wiring, plumbing, and flue connections must be adhered to. In the absence of local codes, the installation must conform with latest edition of the National Fuel Gas Code ANSI Z223.1 • National Installation Code, CAN/CGA B149.1. The latest code may be obtained from the American Gas Association Laboratories, 400 N. Capitol St. NW, Washington D.C. 20001, 1-800-699-9277 or www.aga.org

These furnaces have been classified as Fan Assisted Combustion system CATEGORY I furnaces as required by ANSI Z21.47 "latest edition" and CAN/CGA 2.3. Therefore they do not require any special provisions for venting other than what is indicated in these instructions.

WARNING

FIRE OR EXPLOSION HAZARD

Failure to follow the safety warnings exactly could result in serious injury, death or property damage. Improper servicing could result in dangerous operation, serious injury, death, or property damage.

⚠ WARNING

CARBON MONOXIDE POISONING HAZARD

Failure to follow the steps outlined below for each appliance connected to the venting system being placed into operation could result in carbon monoxide poisoning or death.

The following steps shall be followed for each appliance connected to the venting system being placed into operation, while all other appliances connected to the venting system are not in operation:

Seal any unused openings in the venting system.

1. Inspect the venting system for proper size and horizontal pitch, as required in the National Fuel Gas Code, ANSI Z223.1/NFPA 54 or the CAN/CGA B149 Installation Codes and these instructions. Determine that there is no blockage or restriction, leakage, corrosion and other deficiencies which could cause an unsafe condition.
2. As far as practical, close all building doors and windows and all doors between the space in which the appliance(s) connected to the venting system are located and other deficiencies which could cause an unsafe condition.
3. Close fireplace dampers.
4. Turn on clothes dryers and any appliance not connected to the venting system. Turn on any exhaust fans, such as range hoods and bathroom exhausts, so they are operating at maximum speed. Do not operate a summer exhaust fan.
5. Follow the lighting instructions. Place the appliance be-ing inspected into operation. Adjust the thermostat so appliance is operating continuously.
6. If improper venting is observed during any of the above tests, the venting system must be corrected in accordance with the National Fuel Gas Code, ANSI Z221.1/NFPA 54 and/or CAN/CGA B149 Installation Codes.
7. After it has been determined that each appliance connected to the venting system properly vents where tested as outlined above, return doors, windows, exhaust fans, fireplace dampers and any other gas-fired burning appliance to their previous conditions of use.

Contents

Safety Section	2
General Installation Instructions	2
Location and Clearances	4
Outline Drawings	5
Upflow Installation	7
Downflow Installation	7
Horizontal Installation	7
Air for Combustion and Ventilation	8
Duct Connections	10
Return Air Filter	11
General Venting Instructions	12
Venting into a Masonry Chimney	13
Field Wiring Diagrams	15
Electrical Connections	16
Gas Piping	17
Sequence of Operation	17
Start-up and Adjustment	17
Combustion and Input Check	17
High Altitude Derate	19
Lighting Instructions	20
Control and Safety Switch Adjustment	20
Operating Information	20
Integrated Furnace Control Error flash Codes	21
Periodic Servicing Requirements	22
Airflow Tables	23

⚠ CAUTION

To prevent shortening its service life, the furnace should not be used as a "Construction Heater" during the finishing phases of construction until the requirements listed in item 9, a-g of the safety section of this publication have been met. Condensate in the presence of chlorides and fluorides from paint, varnish, stains, adhesives, cleaning compounds, and cement create a corrosive condition which may cause rapid deterioration of the heat exchanger.

⚠ WARNING

These furnaces are not approved or intended for installation in manufactured (mobile) housing, trailers, or recreational vehicles. Failure to follow this warning could result in property damage, personal injury, or death.

⚠ CAUTION

Do NOT install the furnace in a corrosive or contaminated atmosphere.

⚠ WARNING

Do NOT install the furnace directly on carpeting, tile or other combustible material other than wood flooring. For vertical downflow application, subbase (BAYBASE205) must be used between the furnace and combustible flooring. When the downflow furnace is installed vertically with a cased coil, a subbase is not required.

⚠ WARNING

EXPLOSION HAZARD!

PROPANE GAS IS HEAVIER THAN AIR AND MAY COLLECT IN ANY LOW AREAS OR CONFINED SPACES. IN ADDITION, ODORANT FADE MAY MAKE THE GAS UNDETECTABLE EXCEPT WITH A WARNING DEVICE. IF THE GAS FURNACE IS INSTALLED IN A BASEMENT, AN EXCAVATED AREA OR A CONFINED SPACE, IT IS STRONGLY RECOMMENDED TO CONTACT A GAS SUPPLIER TO INSTALL A GAS DETECTING WARNING DEVICE IN CASE OF A GAS LEAK.

NOTE: The manufacturer of your furnace does not test any detectors and makes no representations regarding any brand or type of detector

LOCATION AND CLEARANCES

The location of the furnace is normally selected by the architect, the builder, or the installer. However, before the furnace is moved into place, be sure to consider the following requirements:

1. Is the location selected as near the chimney or vent and as centralized for heat distribution as practical?
2. Do all clearances between the furnace and enclosure equal or exceed the minimums stated in Clearance Table on the Outline Drawings.
3. Is there sufficient space for servicing the furnace and other equipment? A minimum of 24 inches front accessibility to the furnace must be provided. Any access door or panel must permit removal of the largest component.
4. Are there at least 3 inches of clearance between the furnace combustion air openings in the front panel and any closed panel or door provided?
5. Are the ventilation and combustion air openings large enough and will they remain unobstructed? If outside air is used, are the openings set above the highest snow accumulation level? (See the Air for Combustion and Ventilation section)
6. Allow sufficient height in supply plenum above the furnace to provide for cooling coil installation, if the cooling coil is not installed at the time of this furnace installation.
7. A furnace shall be installed so electrical components are protected from water.
8. If the furnace is installed in a **residential garage**, it must be installed so that the burners, and the ignition source are located not less than 18 inches above the floor and the furnace must be located or protected to avoid physical damage from vehicles.

OUTLINE DRAWINGS - UPFLOW/HORIZONTAL

For the M801P Series Furnaces

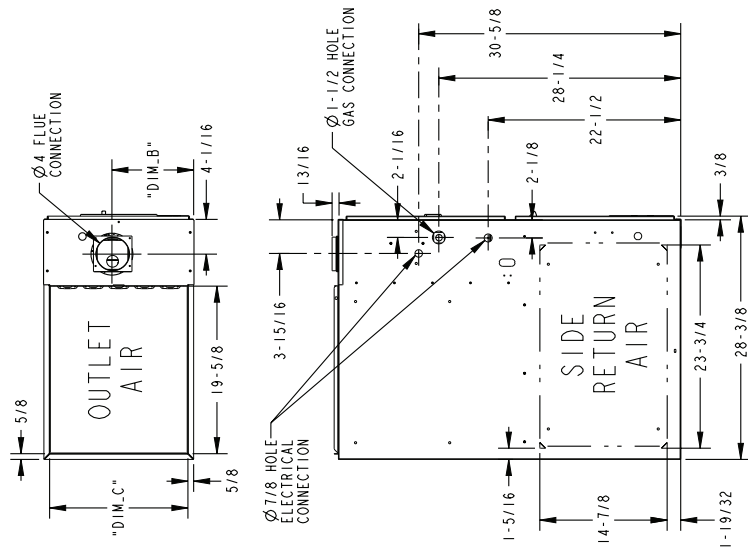

(ALL DIMENSIONS ARE IN INCHES)

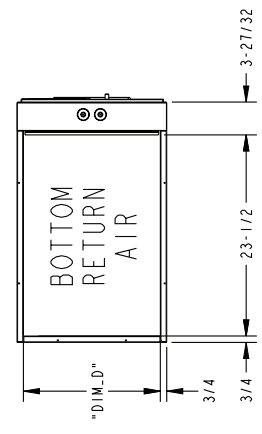
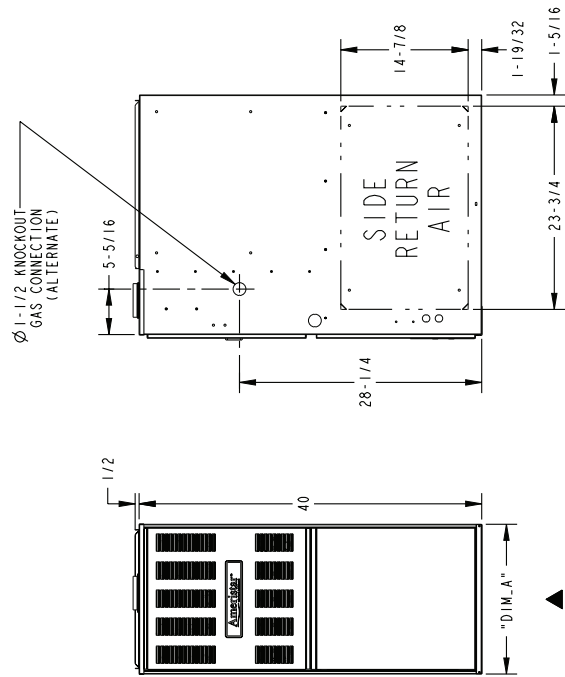

MINIMUM CLEARANCE TO COMBUSTIBLE MATERIALS	
UPFLOW-CLOSED	
LEFT SIDE	0 IN.
RIGHT SIDE	+0 IN.
FLUE	#6 IN.
FRONT	3 IN. (SEE NOTE 1)
BACK	0 IN.
TOP	1 IN.
HORIZONTAL-CLOSED (SEE NOTE 2)	
TOP	+2 IN.
BACK	3 IN.
SIDES	1 IN.
FRONT	18 IN. (SEE NOTE 1)
HORIZONTAL-ALCOVE (SEE NOTE 2)	
FLUE	+1 IN.
BACK	0 IN.
SIDES	0 IN.
FRONT	18 IN.

NOTES:

- 1) MINIMUM CLEARANCE TO FRONT ON M801P140DU60 IS 6 INCHES.
- 2) MAY BE INSTALLED ON COMBUSTIBLE FLOOR WHEN TYPE B-1 VENT IS USED.

MODEL	DIM "A"	DIM "B"	DIM "C"	DIM "D"
M801P040AU24**	14-1/2"	9-5/8"	13-1/4"	13"
M801P060AU36**	17-1/2"	9-5/8"	16-1/4"	16"
M801P080BU36**	21"	13-1/16"	19-3/4"	19-1/2"
M801P100BU36**	24-1/2"	15-5/16"	23-1/4"	23"

** May be "AAA" through "ZZZ"

M801P OUTLINE DRAWING - DOWNFLOWHORIZONTAL

For the M801P Series Furnaces

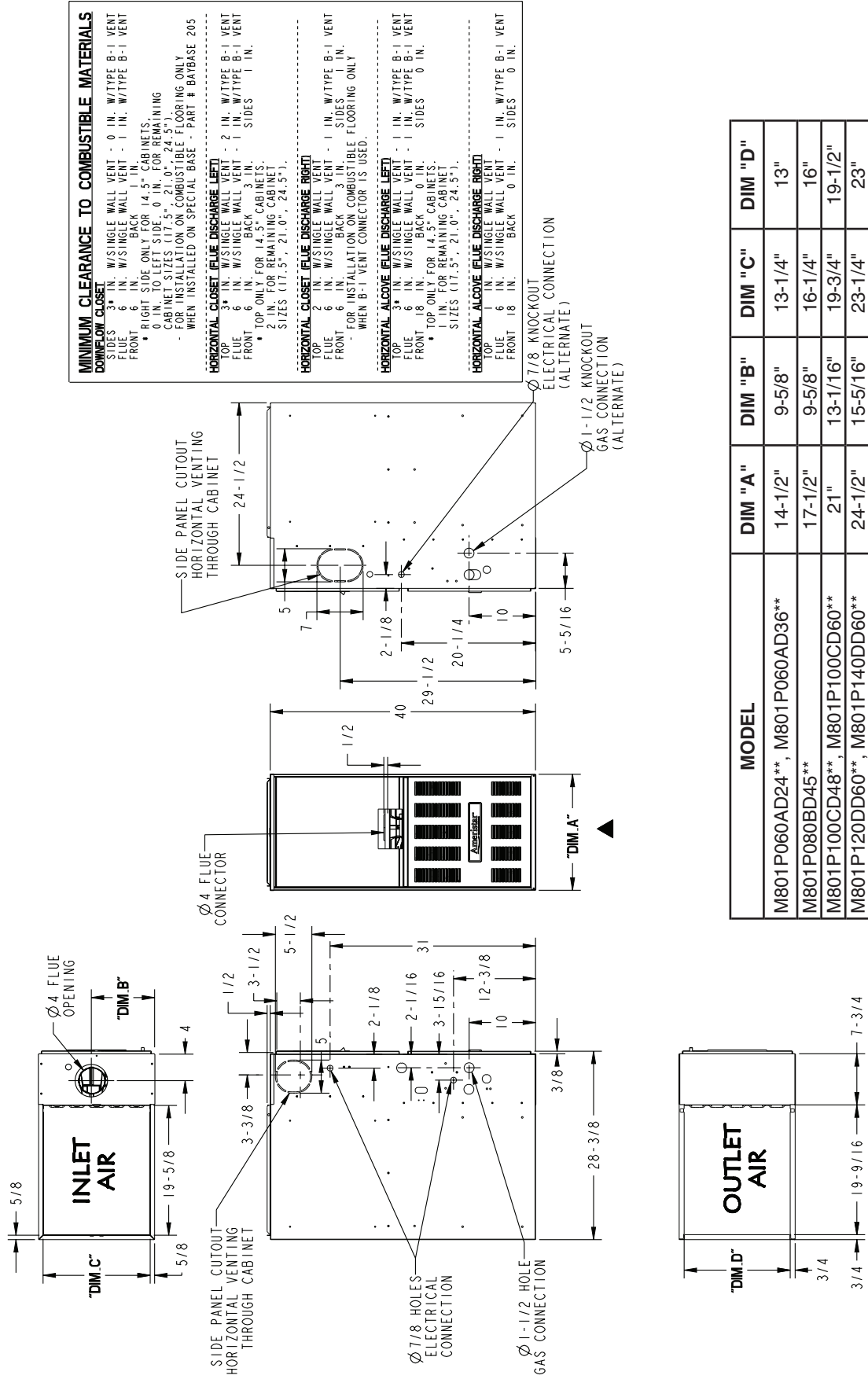

MODEL	DIM "A"	DIM "B"	DIM "C"	DIM "D"
M801P060AD24**, M801P060AD36**	14-1/2"	9-5/8"	13-1/4"	13"
M801P080BD45**	17-1/2"	9-5/8"	16-1/4"	16"
M801P100CD48**, M801P100CD60**	21"	13-1/16"	19-3/4"	19-1/2"
M801P120DD60**, M801P140DD60**	24-1/2"	15-5/16"	23-1/4"	23"

** May be "AAA" through "ZZZ"

UPFLOW INSTALLATION

The coil is always placed downstream of the furnace airflow. Apply gasket material (duct seal field supplied) to ALL mating surfaces between the furnace and the coil case.

NOTE: The top flanges on the furnace must be bent 90 degrees upward to allow the coil attachment.

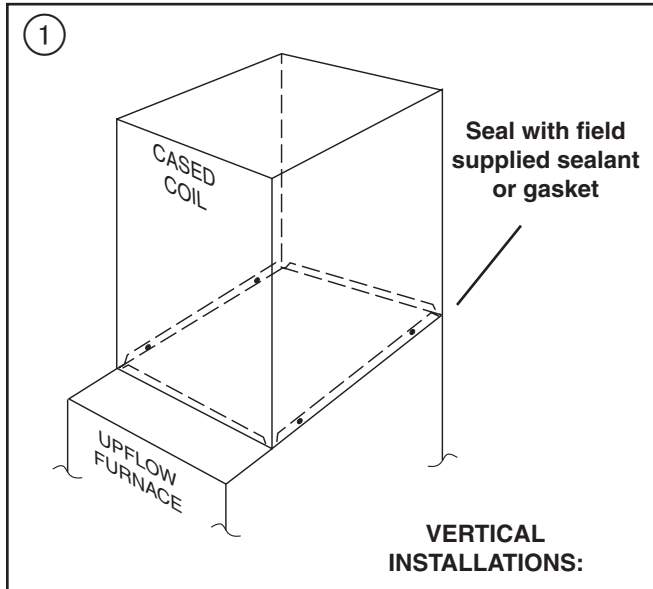

Required floor opening: (DOWNFLOW)

Figure 3 and Table 1

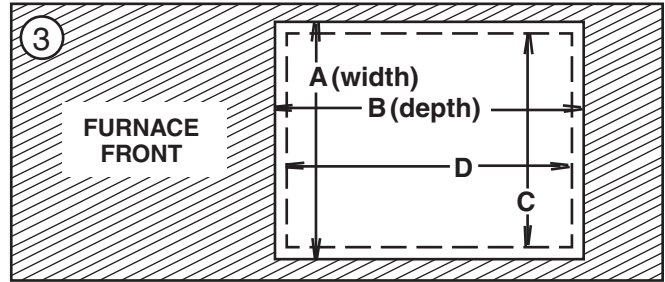

CABINET WIDTH	RETURN DUCT WIDTH	FLOOR OPENING		PLENUM OPENING	
		"A"	"B"	"C"	"D"
14-1/2"	13-1/4"	13-5/8"	20-1/8"	12-5/8"	19-3/8"
17-1/2"	16-1/4"	16-5/8"	20-1/8"	15-5/8"	19-3/8"
21"	19-3/4"	20-1/8"	20-1/8"	19-1/8"	19-3/8"
24-1/2"	23-1/4"	23-5/8"	20-1/8"	22-5/8"	19-3/8"

HORIZONTAL INSTALLATION

The coil and furnace must be fully supported when used in the horizontal position. Three brackets (with screws) are included with downflow furnaces for installation to stabilize and secure the furnace and cased coil in the horizontal position. See Figure 4.

IMPORTANT: The cased coil must be placed downstream of the furnace. In horizontal installations, the apex of the coil may point either toward or away from the furnace. See the coil Installer's Guide for more details.

DOWNFLOW INSTALLATION

⚠ WARNING

Do not install the furnace directly on carpeting, tile or other combustible material other than wood flooring. For vertical downflow application, subbase (BAYBASE205) must be used between the furnace and combustible flooring. When the downflow furnace is installed vertically with a cased coil, a subbase is not required.

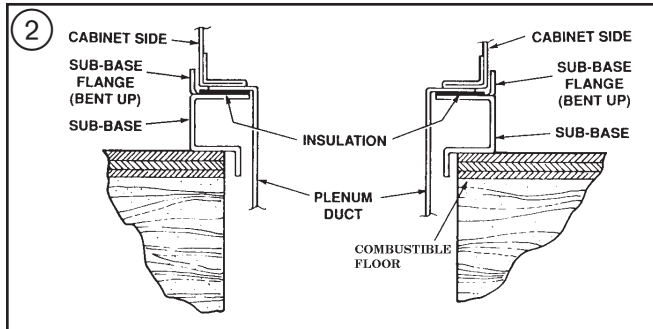

4 CASED COIL CONNECTION BRACKET FOR DOWNFLOW FURNACE IN HORIZONTAL
DOWNFLOW ONLY

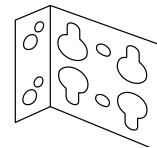

converted to horizontal, aligns and attaches the coil as in Figure 1. However, the coil requires additional support. This furnace may be installed in an attic or crawl space in the horizontal position by placing the furnace on the left or right side (as viewed from the front in the upright position). The horizontal furnace installation in an attic should be on a service platform large enough to allow for proper clearances on all sides and service access to the front of the furnace (See Clearance Table on Outline Drawings and Figure 5).

If the furnace is suspended using perforated steel strap (plumber's strap), it must be supported at all four corners and in the middle at the front of the furnace. The forward most screw on the side of the furnace may be used to connect the strapping (See Figure 6). Line contact is only permissible between lines formed by the intersection of the top and two sides of the furnace casing and the building joists, studs, or framing.

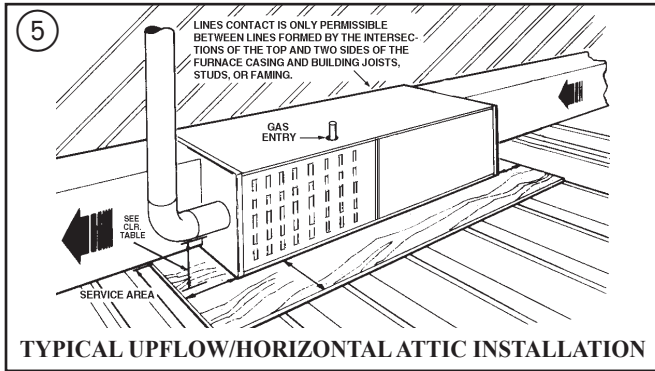

A cutout is provided on both sides of the downflow furnace cabinet to allow a 90° elbow to be attached inside the cabinet and the vent piping to connect there. In horizontal, the downflow furnace may be vented through the top of the cabinet if needed. In vertical configuration, the downflow furnace may be vented using the side cabinet cutouts. This venting configuration could be used if an electronic air cleaner is installed.

When the downflow furnace is vented through the left side of the furnace cabinet in horizontal or vertical configuration, Type B vent pipe must be used within the cabinet.

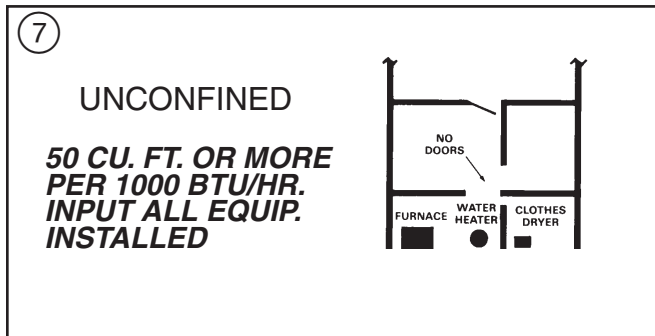
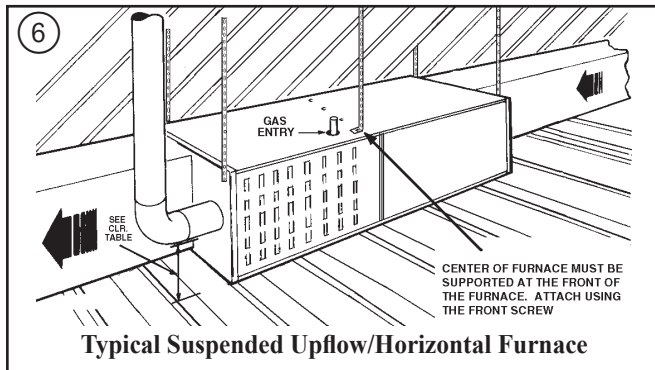

AIR FOR COMBUSTION AND VENTILATION

Adequate flow of combustion and ventilating air must not be obstructed from reaching the furnace. Air openings provided in the furnace casing must be kept free of obstructions which restrict the flow of air. Airflow restrictions affect the efficiency and safe operation of the furnace. Keep this in mind should you choose to remodel or change the area which contains your furnace. Furnaces must have a free flow of air for proper performance.

Provisions for combustion and ventilation air shall be made in accordance with "latest edition" of Section 5.3, Air for Combustion and Ventilation, of the National Fuel Gas Code, ANSI Z223.1, or Sections 7.2, 7.3 or 7.4 of CAN/CGA B149 Installation Codes, and applicable provisions of the local building codes. Special conditions created by mechanical exhausting of air and fireplaces must be considered to avoid unsatisfactory furnace operation.

Furnace locations may be in "confined space" or "unconfined space". Unconfined space is defined in Table 2 and Figure 7. These spaces may have adequate air by infiltration to provide air for combustion, ventilation, and dilution of flue gases. Buildings with tight construction (for example, weather stripping, heavily insulated, caulked, vapor barrier, etc.), may need additional air provided as described for confined space.

Confined spaces are installations with less than 50 cu. ft. of space per 1000 BTU/hr input from all equipment installed. Air for combustion and ventilation requirements can be supplied from inside the building as in Figure 9 or from the outdoors, as in Figure 10.



1. All air from inside the building as in Figure 9: The confined space shall be provided with two permanent openings communicating directly with an additional room(s) of sufficient volume so that the combined volume of all spaces meets the criteria for an unconfined space. The total input of all gas utilization equipment installed in the combined space shall be considered in making this determination. Refer to Table 3, for minimum open areas required.
2. All air from outdoors as in Figure 10: The confined space shall be provided with two permanent openings, one commencing within 12 inches of the top and one commencing within 12 inches of the bottom of the enclosure. The openings shall communicate directly, or by ducts, with the outdoors or spaces (crawl or attic) that freely communicate with the outdoors. Refer to Table 3, for minimum open areas required.

TABLE 2

MINIMUM AREA IN SQUARE FEET FOR UNCONFINED SPACE INSTALLATIONS	
FURNACE MAXIMUM BTUH / INPUT RATING	WITH 8 FOOT CEILING MINIMUM AREA IN SQUARE FEET OF UNCONFINED SPACE
40,000	250
60,000	375
80,000	500
100,000	625
120,000	750
140,000	875

TABLE 3

MINIMUM FREE AREA IN SQUARE INCHES EACH OPENING (FURNACE ONLY)			
Furnace Maximum BTUH/INPUT Rating	Air From Inside	Air From Outside	
		Vertical Duct	Horizontal Duct
40,000	100	10	20
60,000	100	15	30
80,000	100	20	40
100,000	100	25	50
120,000	120	30	60
140,000	140	35	70

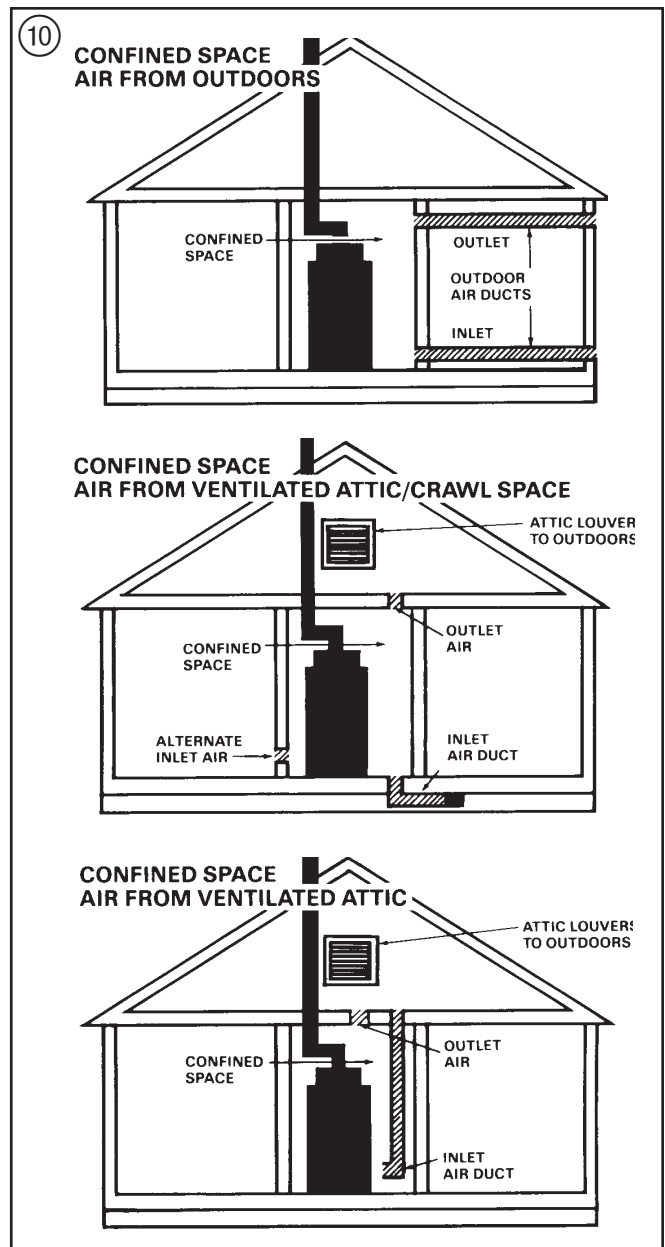
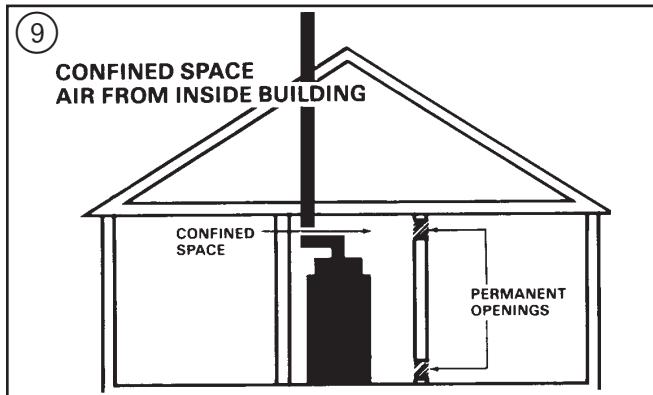

3. The following types of installations will require use of OUTDOOR AIR for combustion, due to chemical exposures:
- * Commercial buildings
 - * Buildings with indoor pools
 - * Furnaces installed in commercial laundry rooms
 - * Furnaces installed in hobby or craft rooms
 - * Furnaces installed near chemical storage areas.
 - * Exposure to the following substances in the combustion air supply will also require OUTDOOR AIR for combustion:
 - * Permanent wave solutions
 - * Chlorinated waxes and cleaners
 - * Chlorine based swimming pool chemicals

- * Water softening chemicals
- * Deicing salts or chemicals
- * Carbon Tetrachloride
- * Halogen type refrigerants
- * Cleaning solvents (such as perchloroethylene)
- * Printing inks, paint removers, varnish, etc.
- * Hydrochloric acid
- * Cements and glues
- * Antistatic fabric softeners for clothes dryers
- * Masonry acid washing materials

DUCT CONNECTIONS

NOTE: *The top flanges on the furnace must be bent 90 degrees upward to allow connection to the ducting.*

Air duct systems should be installed in accordance with standards for air conditioning systems, National Fire Protection Association Pamphlet No. 90. They should be sized in accordance with ACCA Manual D or whichever is applicable.

Central furnaces, when used in connection with cooling units, shall be installed in parallel or on the upstream side of the cooling units to avoid condensation in the heating element, unless the furnace has been specifically approved for downstream installation. With a parallel flow arrangement, the dampers or other means used to control flow of air shall be adequate to prevent chilled air from entering the furnace, and if manually operated, must be equipped with means to prevent operation of either unit unless the damper is in full heat or cool position.

On any job, flexible connections of nonflammable material may be used for return air and discharge connections to prevent transmission of vibration. Though these units have been specifically designed for quiet, vibration free operation, air ducts can act as sounding boards and could, if poorly installed, amplify the slightest vibration to the annoyance level.

When the furnace is located in a utility room adjacent to the living area, the system should be carefully designed with returns which minimize noise transmission through the return air grille. Although these winter air conditioners are designed with large blowers operating at moderate speeds, any blower moving a high volume of air will produce audible noise which could be objectionable when the unit is located very close to a living area. It is often advisable to route the return air ducts under the floor or through the attic. Such design permits the installation of air return remote from the living area (i.e. central hall).

When the furnace is installed so that the supply ducts carry air circulated by the furnace to areas outside the space containing the furnace, the return air shall also be handled by a duct(s) sealed to the furnace and terminating outside the space containing the furnace.

Minimum return air/"air entering" temperature for the furnace is 55° F.

Where there is no complete return duct system, the return connection must be run full size from the furnace to a location outside the utility room, basement, attic, or crawl space.

Do not install return air through the back of the furnace cabinet.

Return Air Duct Connection

All return air duct systems should provide for installation of return air filters.

NOTE: *For Upflow 5 ton airflow models, if the airflow requirement exceeds 1800 CFM, these models will require return air openings and filters on both sides; or 1 side and the bottom; or just the bottom.*

1. Set the furnace in place.
2. For side return installations on upflow models, remove the insulation around the opening in the blower compartment.
3. The side panels on upflow furnaces include locating notches which may be used as guides for cutting an opening for return air. Refer to Figure 11 and the outline drawing in this document for duct connection dimensions for various furnaces.
4. If a 3/4" flange is to be used for attaching the air inlet duct, add to cut where indicated by solid lines in Figure 11. Cut corners diagonally and bend outward to form flange.
5. If flanges are not required, and a filter frame is installed, cut along knockout guidelines.
6. Upflow Furnaces: Filter brackets are available for filter use within the furnace cabinets. Order RTR00133 and CLP00359. If bottom return opening is not used, fabricate and install a sheet metal plate in the bottom of the furnace cabinet

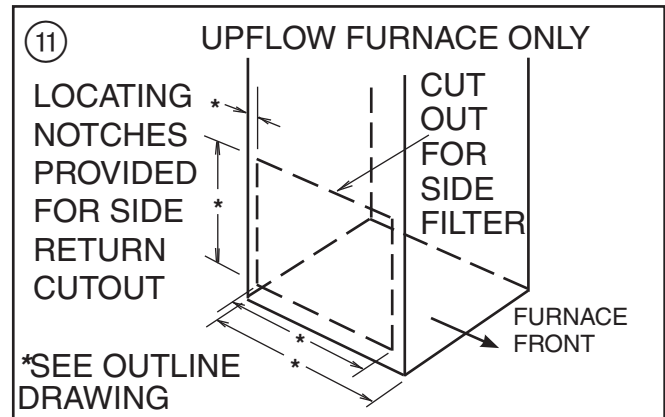

Downflow Furnaces: Brackets must be field supplied. Order BAYBRCKFLT10. Also 2 FLR01185 for 14.5" models, or 2 FLR01186 for 17.5", 21.0" and 24.5" models must be ordered.

When the upflow furnace is installed in the horizontal right or left application and a return duct is attached to the top side as shown in Figure 12, the filter must be installed in a remote location.

Do not install the filter in the return duct directly above the furnace in horizontal applications.

⚠ WARNING

Do NOT install the filter in the return duct directly above the furnace in horizontal applications. Install the filter remotely. Installing the filter directly above the furnace in horizontal applications may cause property damage, serious injury or death.

⚠ WARNING

TO PREVENT INJURY OR DEATH DUE TO CONTACT WITH MOVING PARTS, TURN THE POWER TO THE FURNACE OFF BEFORE SERVICING FILTERS.

When the upflow furnace is installed in the horizontal right or left application and a close coupled (less than 36") return duct is attached to the bottom side of the furnace as shown in Figure 12, securely attach a 1/2" mesh metal hardware cloth protective screen to the inside bottom of the filter grill to prevent personal injury from contacting moving parts when reaching into the return opening to replace the filter.

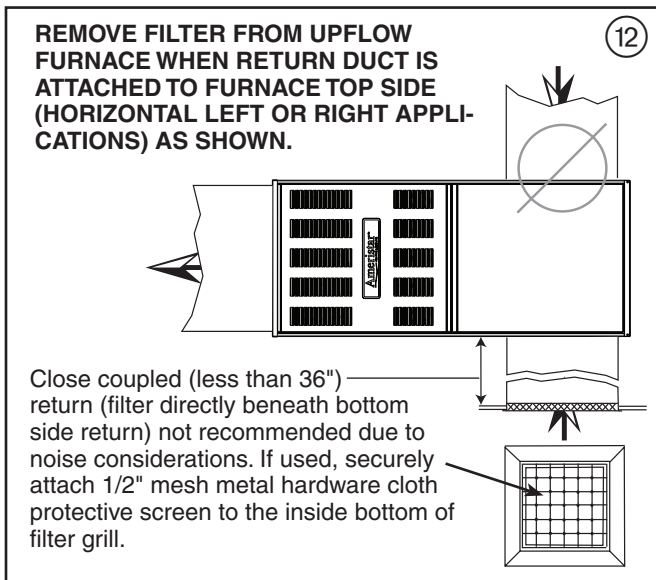

Close coupled (less than 36") return (filter directly beneath bottom side return) is not recommended due to noise considerations.

7. Connect the duct work to the furnace. See Outline Drawing for supply and return duct size and location. Flexible duct connectors are recommended to connect both supply and return air ducts to the furnace. If only the front of the furnace is accessible, it is recommended that both supply and return air plenums are removable.
8. When replacing a furnace, old duct work should be cleaned out. Thin cloths should be placed over the registers and the furnace fan should be run for 10 minutes. Don't forget to remove the cloths before you start the furnace.

RETURN AIR FILTER

These furnaces require high velocity type air filters which may be located within the furnace blower compartment for UPFLOW furnaces in either a BOTTOM or SIDE (left side or right side) return air inlet. See Figures 13 and 14. Some filters may need to be trimmed for side or bottom filter use.

NOTE: On upflow 5 ton airflow models, if the airflow requirement exceeds 1800 CFM, these models will require return air openings and filters on both sides; OR 1 side and the bottom; OR just the bottom.

NOTE: Upflow models only - Installation of the alternate bottom filter kit requires the bottom flange to be bent flat.

Optional downflow furnace filters must be located outside the furnace cabinet. Typical installations are shown in Figures 14 and 15. Tables 5 and 6 provide information for installation of the filter retaining brackets shipped with downflow furnaces.

TABLE 4

MODEL	CABINET WIDTH	REQUIRED FILTER SIZE FOR BOTTOM
M801P040AU24AA M801P060AU24AA M801P060AU36AA	14-1/2"	1 - 14 X 25 X 1
M801P080BU36AA M801P080BU48AA M801P100BU36AA	17-1/2"	1 - 17 X 25 X 1
M801P100CU48AA M801P100CU60AA	21"	1 - 20 X 25 X 1
M801P120DU60AA M801P140DU60AA	24-1/2"	1 - 24 X 20 X 1
M801P060AD24AA M801P060AD36AA	14-1/2"	BAYBRCKFLT10 2 - FLR01185
M801P080BD45AA	17-1/2"	BAYBRCKFLT10 2 - FLR01186
M801P100CD48AA M801P100CD60AA	21"	BAYBRCKFLT10 2 - FLR01186
M801P120DD60AA M801P140DD60AA	24-1/2"	BAYBRCKFLT10 2 - FLR01186

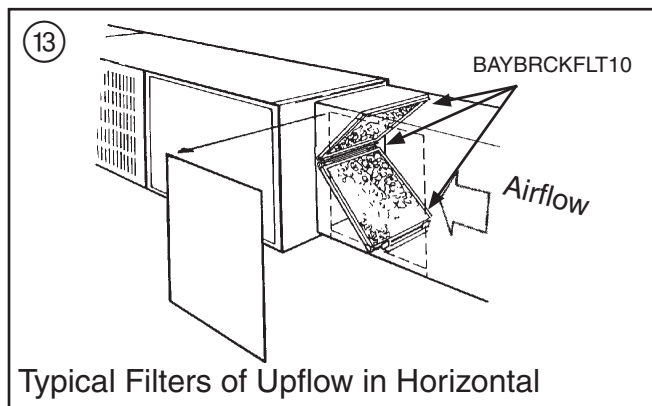

Important: When using the supplied high velocity filters, the filter support base must be installed into the furnace duct flange prior to ductwork installation.

Remove the brackets from the blower compartment. They are wrapped in foam and taped to the side of the downflow unit.

Remove the four screws securing the top panel. Save screws.

Slide the top panel forward approximately 1".

With support tabs facing up, install the filter base by inserting one end tab into the duct flange at the rear of the furnace.

Slide the top panel back to its original position, engaging the other end tab in the slot. Replace screws.

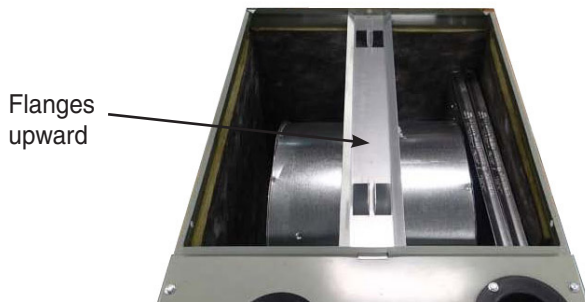
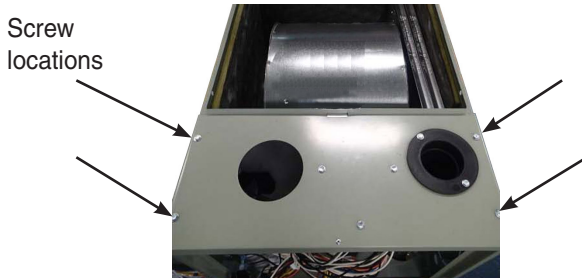
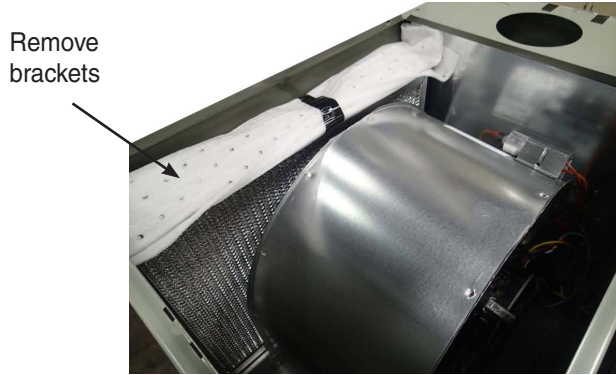

TABLE 5

CABINET WIDTH	FILTER SIZE	FILTER BRACKET LOCATION *
14-1/2"	2 - 14X20X1	12-7/8"
17-1/2"	2 - 16X20X1	14-3/8"
21"	2 - 16X20X1	13-1/8"
24-1/2"	2 - 16X20X1	11-5/8"

* Location dimension is from end of duct to the screw holes for the bracket.

TABLE 6

CABINET WIDTH	RETURN DUCT WIDTH	FILTER ACCESS OPENING - DIMENSION "A"	FILTER ACCESS OPENING - DIMENSION "B"
14-1/2"	13-1/4"	12"	14"
17-1/2"	16-1/4"	15"	14"
21"	19-3/4"	19-1/2"	14"
24-1/2"	23-1/4"	22"	14"

GENERAL VENTING INSTRUCTIONS

VENT PIPING

These furnaces have been classified as Fan-Assisted Combustion System, Category I furnaces under the "latest edition" provisions of ANSI Z21.47 and CAN/CGA 2.3 standards. Category I furnaces operate with a non-positive vent static pressure and with a flue loss of not less than 17 percent.

NOTE: If desired, a side wall termination can be accomplished through the use of an "add-on" draft inducer. The inducer must be installed according to the inducer manufacturer's instructions. Set the barometric pressure relief to achieve -0.02 inch water column.

NOTE: When the downflow furnace is vented through the left side of the furnace cabinet using the provided cutout, Type B vent piping must be used.

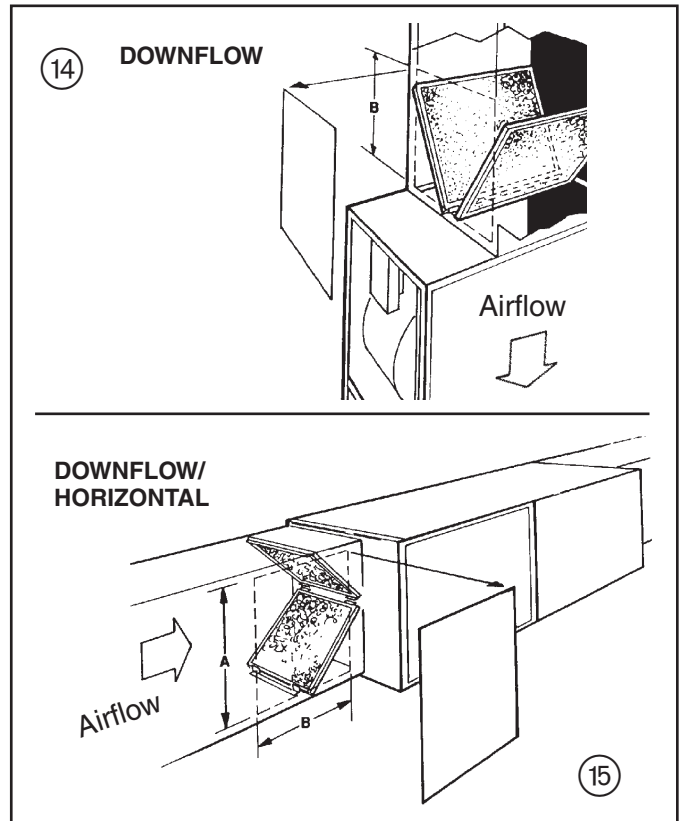

⚠ WARNING

CARBON MONOXIDE POISONING HAZARD

Failure to follow the steps outlined below for each appliance connected to the venting system being placed into operation could result in carbon monoxide poisoning or death.

The following steps shall be followed for each appliance connected to the venting system being placed into operation, while all other appliances connected to the venting system are not in operation:

1. Seal any unused openings in the venting system.
2. Inspect the venting system for proper size and horizontal pitch, as required in the National Fuel Gas Code, ANSI Z223.1/NFPA 54 or the CAN/CGA B149 Installation Codes and these instructions. Determine that there is no blockage or restriction, leakage, corrosion and other deficiencies which could cause an unsafe condition.
3. As far as practical, close all building doors and windows and all doors between the space in which the appliance(s) connected to the venting system are located and other spaces of the building.
4. Close fireplace dampers.
5. Turn on clothes dryers and any appliance not connected to the venting system. Turn on any exhaust fans, such as range hoods and bathroom exhausts, so they are operating at maximum speed. Do not operate a summer exhaust fan.
6. Follow the lighting instructions. Place the appliance being inspected into operation. Adjust the thermostat so appliance is operating continuously.
7. If improper venting is observed during any of the above tests, the venting system must be corrected in accordance with the National Fuel Gas Code, ANSI Z221.1/NFPA 54 and/or CAN/CGA B149 Installation Codes.
8. After it has been determined that each appliance connected to the venting system properly vents where tested as outlined above, return doors, windows, exhaust fans, fireplace dampers and any other gas-fired burning appliance to their previous conditions of use.

The furnace shall be connected to a factory built chimney or vent complying with a recognized standard, or a masonry or concrete chimney lined with a lining material acceptable to the authority having jurisdiction.

⚠ WARNING

Furnace venting into an unlined masonry chimney or concrete chimney is prohibited.

Failure to follow this warning could result in property damage, personal injury, or death.

VENTING INTO A MASONRY CHIMNEY

If the chimney is oversized, the liner is inadequate, or flue-gas condensation is a problem in your area, consider using the chimney as a pathway or chase for type “B” vent or flexible vent liner. If flexible liner material is used, size the vent using the “B” vent tables, then reduce the maximum capacity by 20% (multiply 0.80 times the maximum capacity).

Internal Masonry Chimneys

Venting of fan assisted appliances into a lined, internal masonry chimney is allowed only if it is common vented with at least one natural draft appliance; OR, if the chimney is lined with type “B”, double wall vent or suitable flexible liner material (See Table 7).

⚠ WARNING

The chimney liner must be thoroughly inspected to insure no cracks or other potential areas for flue gas leaks are present in the liner. Liner leaks will result in early deterioration of the chimney.

Failure to follow this warning could result in carbon monoxide poisoning or death.

TABLE 7

MASONRY CHIMNEY VENTING				
Type Furnace	Tile Lined Chimney		Chimney Lining	
	Internal	External	“B” Vent	Flexible Metal Liner
Single Fan Assist	No	No	Yes	Yes*
Fan Assist + Fan Assist	No	No	Yes	Yes*
Fan Assist + Natural	Yes	No	Yes	Yes*

* Flexible chimney liner size is determined by using the type “B” vent size for the available BTUH input, then reducing the maximum capacity by 20% (multiply maximum capacity times 0.80). The minimum capacity is the same as shown in the “B” vent tables.

External Masonry Chimney

⚠ WARNING

CARBON MONOXIDE POISONING HAZARD

This masonry chimney kit shall NOT be installed on any furnaces with 40,000 BTU/H inputs or any downflow models. Failure to follow this warning could result in carbon monoxide poisoning, personal injury, or death.

NOTE: Masonry Chimney Kit BAYVENT800B may be used with these furnaces (Upflow model furnaces 60,000 BTU/H and above only) to allow venting into an external masonry chimney. Refer to BAYVENT800B Installer's Guide for application requirements. The following section does not apply if BAYVENT800B (Masonry Chimney Kit) is used. All instructions with the kit must be followed.

Venting of fan assisted appliances into external chimneys (one or more walls exposed to outdoor temperatures), requires the chimney be lined with type "B", double wall vent or suitable flexible chimney liner material. This applies in all combinations of common venting as well as for fan assisted appliances vented alone.

The following installation practices are recommended to minimize corrosion caused by condensation of flue products in the furnace and flue gas system.

⚠ WARNING

CARBON MONOXIDE POISONING HAZARD

Failure to follow the installation instructions for the venting system being placed into operation could result in carbon monoxide poisoning or death.

1. Avoid an excessive number of bends.
2. Horizontal runs should pitch upward at least 1/4" per foot.
3. Horizontal runs should be as short as possible.
4. All vent pipe or connectors should be securely supported and must be inserted into, but not beyond the inside wall at the chimney vent.
5. When vent connections must pass through walls or partitions of combustible material, a thimble must be used and installed according to local codes.
6. Vent pipe through the roof should be extended to a height determined by National Fuel Gas Code or local codes. It should be capped properly to prevent rain water from entering the vent. Roof exit should be waterproofed.
7. Use type "B" double wall vent when vent pipe is routed through cool spaces (below 60° F.).
8. Where long periods of airflow are desired for comfort, use long fan cycles instead of continuous airflow.
9. Apply other good venting practices as stated in the venting section of the National Fuel Gas Code ANSI Z223.1 "latest edition".
10. Vent connectors serving appliance vented by natural draft or non-positive pressure shall not be connected into any portion of a mechanized draft system operating under positive pressure.
11. Horizontal pipe runs must be supported by hangers, straps or other suitable material in intervals at a minimum of every 3 feet of pipe.
12. A furnace shall not be connected to a chimney or flue serving a separate appliance designed to burn solid fuel.
13. The flow area of the largest section of vertical vent or chimney shall not exceed 7 times the smallest listed appliance categorized vent area, flue collar area, or draft hood outlet area unless designed in accordance with approved engineering methods.

$$\text{Maximum Vent or Tile Lined Chimney Flow Area} = \frac{\pi(D^*)^2}{4} \times 7$$

*Drafthood outlet diameter, flue collar diameter, or listed appliance categorized vent diameter.

TABLE 8

GAS VENT TERMINATION	
ROOF PITCH	MINIMUM HEIGHT
FLAT TO 7/12	1.0 FEET *
OVER 7/12 TO 8/12	1.5 FEET
OVER 8/12 TO 9/12	2.0 FEET
OVER 9/12 TO 10/12	2.5 FEET
OVER 10/12 TO 11/12	3.25 FEET
OVER 11/12 TO 12/12	4.0 FEET
OVER 12/12 TO 14/12	5.0 FEET
OVER 14/12 TO 16/12	6.0 FEET
OVER 16/12 TO 18/12	7.0 FEET
OVER 18/12 TO 20/12	7.5 FEET
OVER 20/12 TO 22/12	8.0 FEET

* THIS REQUIREMENT COVERS MOST INSTALLATIONS

Carbon monoxide, fire or smoke can cause serious bodily injury, death, and/ or property damage.

A variety of potential sources of carbon monoxide can be found in a building or dwelling such as gas-fired clothes dryers, gas cooking stoves, water heaters, furnaces and fireplaces. The U.S. Consumer Product Safety Commission recommends that users of gas-burning appliances install carbon monoxide detectors as well as fire and smoke detectors per the manufacturer's installation instructions to help alert dwelling occupants of the presence of fire, smoke or unsafe levels of carbon monoxide. These devices should be listed by Underwriters Laboratories, Inc. *Standards for Single and Multiple Station Carbon Monoxide Alarms, UL 2034* or CSA International Standard, *Residential Carbon Monoxide Alarming Devices, CSA 6.19*.

NOTE: The manufacturer of your furnace does not test any detectors and makes no representations regarding any brand or type of detector.

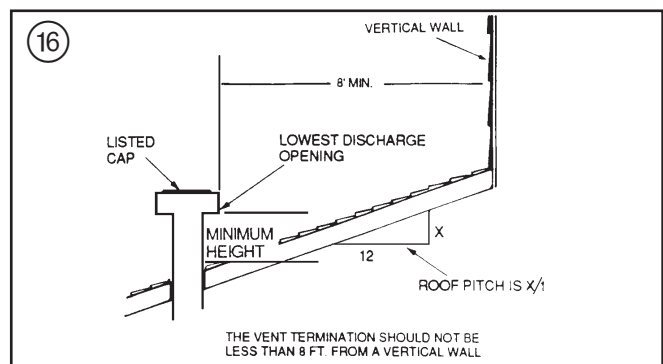

FIELD WIRING DIAGRAMS

FIELD WIRING DIAGRAM FOR 1 STAGE FURNACE
1 STAGE HEATING
USING A 1 STAGE HEATING THERMOSTAT
NO COOLING

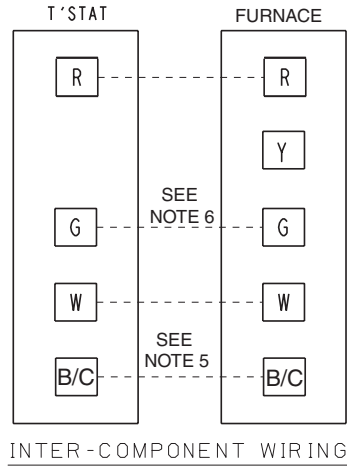

NOTES

1. BE SURE POWER SUPPLY AGREES WITH EQUIPMENT NAMEPLATE(S).
2. LOW VOLTAGE (24V.) WIRING TO BE NO. 18 AWG MIN.
3. GROUNDING OF EQUIPMENT MUST COMPLY WITH LOCAL CODES.
4. SET THERMOSTAT HEAT ANTICIPATOR PER UNIT WIRING DIAGRAM.
5. THIS CONNECTION IS ONLY USED FOR THERMOSTATS REQUIRING CONNECTION TO THE 24 V. POWER SUPPLY. (COMMON)
6. WHEN A HEATING THERMOSTAT (WITHOUT FAN SWITCH) IS USED, NO WIRING ON "G" TERMINAL OF IFC IS USED.

INTER-COMPONENT WIRING

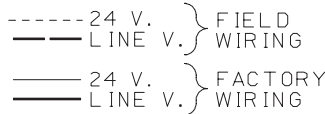

TO 115 V 1 PH.,
60 HZ., POWER
SUPPLY PER
LOCAL CODES

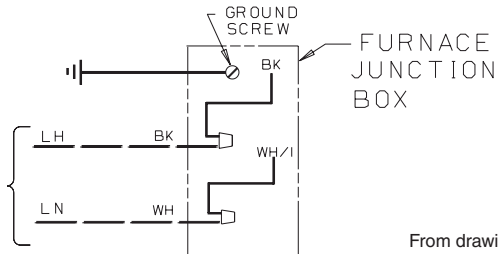

From drawing B342026 Rv 0

FIELD WIRING DIAGRAM FOR 1 STAGE FURNACE
1 STAGE HEATING, 1 STAGE COOLING
USING A 1 STAGE HEATING, 1 STAGE COOLING THERMOSTAT
(OUTDOOR SECTION WITHOUT TRANSFORMER)

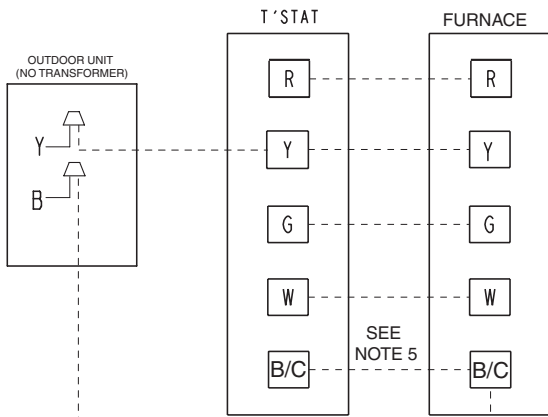

NOTES

1. BE SURE POWER SUPPLY AGREES WITH EQUIPMENT NAMEPLATE(S).
2. LOW VOLTAGE (24V.) WIRING TO BE NO. 18 AWG MIN.
3. GROUNDING OF EQUIPMENT MUST COMPLY WITH LOCAL CODES.
4. SET THERMOSTAT HEAT ANTICIPATOR PER UNIT WIRING DIAGRAM.
5. THIS CONNECTION IS ONLY USED FOR THERMOSTATS REQUIRING CONNECTION TO THE 24 V. POWER SUPPLY. (COMMON)

INTER-COMPONENT WIRING

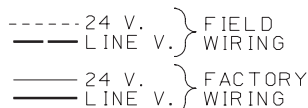

TO 115 V 1 PH.,
60 HZ., POWER
SUPPLY PER
LOCAL CODES

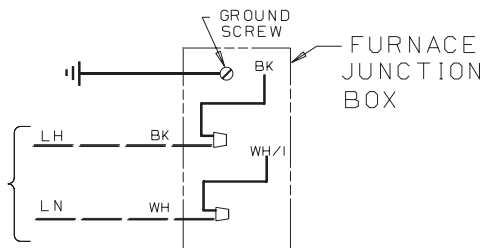

From drawing B342023 Rv 0

ELECTRICAL CONNECTIONS

⚠ WARNING

The cabinet must have an uninterrupted or unbroken ground according to National Electrical Code, ANSI/NFPA 70 - "latest edition" and Canadian Electrical Code, CSA C22.1 or local codes to minimize personal injury if an electrical fault should occur. Failure to follow this warning could result in an electrical shock, fire, injury, or death.

⚠ CAUTION

The integrated furnace control is polarity sensitive. The hot leg of the 115 VAC power must be connected to the BLACK field lead.

⚠ WARNING

To prevent injury or death due to electrical shock or contact with moving parts, lock unit disconnect switch in the open position before servicing the unit. Failure to follow this warning could result in electrical shock, personal injury, or death.

Make wiring connections to the unit as indicated on enclosed wiring diagram. As with all gas appliances using electrical power, this furnace shall be connected into a permanently live electric circuit. It is recommended that it be provided with a separate "circuit protection device" electric circuit. The furnace must be electrically grounded in accordance with local codes or in the absence of local codes with the National Electrical Code, ANSI/ NFPA 70 "latest edition" or Canadian Electrical Code, CSA C22.1, if an external electrical source is utilized.

All field supplied wiring must conform with the temperature limitation for Type T wire [63° F (35° C)], when installed in accordance with these instructions and wiring diagrams supplied with the furnace. A disconnecting means must be located within sight from, and readily accessible to, the furnace. Refer to the SERVICE FACTS literature for unit wiring diagrams in addition to the diagram inside the blower door.

⚠ WARNING

FIRE OR EXPLOSION HAZARD

Failure to follow the safety warnings exactly could result in serious injury, death or property damage. Never test for gas leaks with an open flame. Use a commercially available soap solution made specifically for the detection of leaks to check all connections. A fire or explosion may result causing property damage, personal injury, or loss of life.

⚠ WARNING

TO PREVENT AN EXPLOSION OR POSSIBLE INJURY, DEATH AND EQUIPMENT DAMAGE, DO NOT STORE COMBUSTIBLE MATERIALS, GASOLINE OR OTHER FLAMMABLE VAPORS OR LIQUIDS NEAR THE UNIT.

IMPORTANT:

A sediment trap must be installed in the gas line before the furnace gas valve. The sediment trap must be located as close to the furnace cabinet as practical.

⑰

LEFT SIDE PIPING (STANDARD)

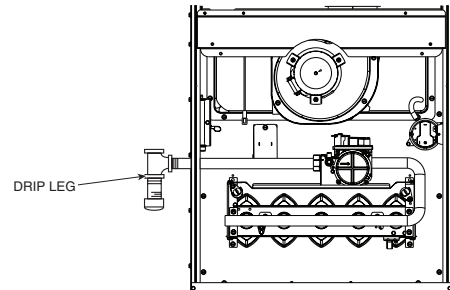

RIGHT SIDE PIPING (OPTIONAL)

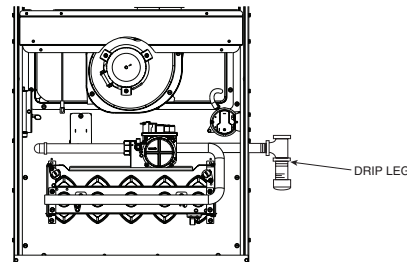

TOP VIEW OF RIGHT SIDE PIPING

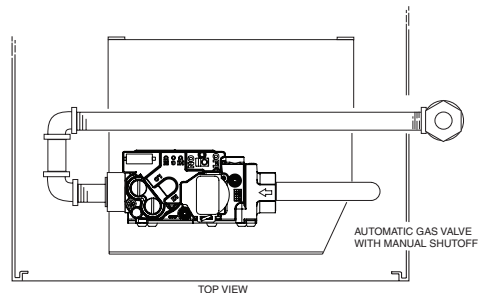

GAS PIPING

⚠ WARNING

FIRE - EXPLOSION HAZARD

DO NOT RUN FLEXIBLE GAS LINE THROUGH THE FURNACE CABINET WALL. FAILURE TO FOLLOW THIS WARNING COULD RESULT IN PROPERTY DAMAGE, SERIOUS PERSONAL INJURY, OR DEATH.

This unit is shipped standard for left side installation of gas piping. A piping cutout is also provided in the right side for an alternate piping arrangement. The installation of piping shall be in accordance with piping codes and the regulations of the local gas company. Pipe joint compound must be resistant to the chemical reaction with liquefied petroleum gases. Refer to piping Table 9 for delivery sizes.

NOTE: Refer to local codes and the National Fuel Gas Code, current edition, for gas pipe requirements.

The furnace and its individual shut-off valve must be disconnected from the gas supply piping system during any pressure testing of that system at test pressures in excess of 1/2 psig.

The furnace must be isolated from the gas supply piping by closing its individual manual shut-off valve during any pressure testing of the gas supply piping system at test pressures equal to or less than 1/2 psig.

⚠ CAUTION

Use a backup wrench on the gas valve when installing gas piping to prevent damage to the gas valve and manifold assembly.

NOTE: Maximum pressure to the gas valve for natural gas is 13.8" W.C. Minimum pressure is 5.0" W.C. Maximum pressure to the gas valve for propane is 13.8" W.C. Minimum pressure is 11.0" W.C.

All gas fittings must be checked for leaks using a soapy solution before lighting the furnace.

DO NOT CHECK WITH AN OPEN FLAME!

The following warning complies with the State of California law, Proposition 65.

⚠ WARNING

HAZARDOUS GASES!

EXPOSURE TO FUEL SUBSTANCES OR BY PRODUCTS OF INCOMPLETE FUEL COMBUSTION IS BELIEVED BY THE STATE OF CALIFORNIA TO CAUSE CANCER, BIRTH DEFECTS, OR OTHER REPRODUCTIVE HARM.

SEQUENCE OF OPERATION

Thermostat call for heat

R and W thermostat contacts close signaling the control module to run its self-check routine. After the control module has verified

that the pressure switch contacts are open and the limit switch(es) contacts are closed, the draft blower will be energized.

As the induced draft blower comes up to speed, the pressure switch contacts will close and the ignitor warm up period will begin. The ignitor will heat for approx. 17 seconds, then the gas valve is energized to permit gas flow to the burners. The flame sensor confirms that ignition has been achieved within the 6 second ignition trial period.

After the flame sensor confirms that ignition has been achieved, the delay fan ON period (fixed at 45 seconds) begins timing. After the delay of 45 seconds, the indoor blower motor will be energized and will continue to run during the heating cycle.

When the thermostat is satisfied, R and W thermostat contacts open, the gas valve will close, the flames will extinguish, and the induced draft blower will be de-energized. The indoor blower motor will continue to run for the fan off period (fixed at 100 seconds), then will be de-energized by the control module.

⚠ WARNING

FIRE OR EXPLOSION HAZARD

Failure to follow the safety warnings exactly could result in serious injury, death or property damage. Never test for gas leaks with an open flame. Use a commercially available soap solution made specifically for the detection of leaks to check all connections. A fire or explosion may result causing property damage, personal injury, or loss of life

START-UP AND ADJUSTMENT

Preliminary Inspections

With gas and electrical power "OFF"

1. Duct connections are properly sealed
2. Filters are in place
3. Venting is properly assembled
4. Blower door is in place

Turn knob on main gas valve within the unit to the "OFF" position. Turn the external gas valve to "ON". Purge the air from the gas lines. After purging, check all gas connections for leaks with a soapy solution – **DO NOT CHECK WITH AN OPEN FLAME**. Allow 5 minutes for any gas that might have escaped to dissipate. LP Gas, being heavier than air, may require forced ventilation. Turn the knob on the gas valve in the unit to the "ON" position.

COMBUSTION AND INPUT CHECK

1. Make sure all gas appliances are off except furnace.
2. Clock the gas meter with the furnace operating (determine the dial rating of the meter) for one revolution.
3. Match the "Sec" column in the gas flow (in cfh) Table 12 with the time clocked.
4. Read "Flow" column opposite number of seconds clocked.

5. Use the following factors if necessary:
 For 1 Cu. Ft. Dial Gas Flow CFH = Chart Flow Reading ÷ 2
 For 1/2 Cu Ft. Dial Gas Flow CFH = Chart Flow Reading ÷ 4
 For 5 Cu. Ft. Dial Gas Flow CFH = 10X Chart Flow Reading ÷ 4
6. Multiply the final figure by the heating value of the gas obtained from the utility company and compare to the nameplate rating. This must not exceed the nameplate rating.

Gas Valve Adjustment

Changes can be made by adjusting the manifold pressure (See Table 14), or changing orifices (orifice change may not always be required). To adjust the manifold pressure:

1. Turn off all electrical power to the system.
2. Attach a manifold pressure gauge with flexible tubing to the outlet pressure boss marked "OUT P" on White-Rodgers gas valve model 36J. See Figure 18 for White-Rodgers gas valve model 36J.
3. Loosen (Do Not remove) the pressure tap test set screw one turn with 3/32" hex wrench.
 - a. The pressure tap adjustment kit (KIT07611) contains a 3/32" hex wrench, a 5/16" hose and a connector and can be ordered through Global Parts.
4. Turn on system power and energize valve.
5. Adjust gas heat by removing adjustment regulator cover screw.
 - a. To increase outlet pressure, turn regulator adjust screw clockwise.
 - b. To decrease outlet pressure, turn the regulator adjust screw counterclockwise.
 - c. Adjust regulator until pressure shown on manometer matches pressure specified in Table 14.
 - d. The input of no more than nameplate rating and no less than 93% of the nameplate rating, unless the unit is derated for high altitude.
 - e. Replace and tighten regulator cover screw securely.
6. Cycle valve several times to verify regulator setting.
 - a. Repeat steps 5-6 if needed.
7. Turn off all electrical power to the system.
8. Remove the manometer and flexible tubing and tighten the pressure tap screw.
9. Using a leak detection solution or soap suds, check for leaks at the pressure outlet boss and pressure tap test screw.
10. Turn on system power and check operation of unit.

⚠ CAUTION

Replace and/ or tighten all plugs removed or loosened when adjusting gas pressure. Leak check the fittings before placing the furnace into regular service. Failure to follow this warning could result in fire, explosion, or property damage.

For LP gases, the final manifold pressure setting shall be 10.5" W.C. with an input of no more than the nameplate rating and no less than 93% of the nameplate rating, unless the unit is derated for altitude. Table 10 lists the main burner orifices shipped with the furnace. If a change of orifices is required to correct the input rate, refer to Table 11.

Input ratings (BTUH) of these furnaces are based on sea level operation and should not be changed at elevations up to 2,000 ft. If the installation is 2,000 ft. or above, the furnace input rate (BTUH) shall be reduced 4% for each 1,000 ft. above sea level. The furnace input rate shall be checked by clocking the gas flow rate (CFH) and multiplying by the heating value obtained from the local utility supplier for the gas being delivered at the

TABLE 9

NATURAL GAS ONLY							
TABLE OF CUBIC FEET PER HOUR OF GAS FOR VARIOUS PIPE SIZES AND LENGTHS							
PIPE SIZE	LENGTH OF PIPE						
	10	20	30	40	50	60	70
1/2	132	92	73	63	56	50	46
3/4	278	190	152	130	115	105	96
1	520	350	285	245	215	195	180
1-1/4	1050	730	590	520	440	400	370

This table is based on pressure drop of 0.3 inch W.C. and 0.6 SP.GR. gas

TABLE 10

ORIFICE SIZES			
INPUT RATING BTUH	NUMBER OF BURNERS	MAIN BURNER ORIFICE DRILL SIZE	
		NAT. GAS	LP GAS
40,000	2	45	56
60,000	3	45	56
80,000	4	45	56
100,000	5	45	56
120,000	6	45	56
140,000	7	45	56

TABLE 11

PART NUMBERS FOR REPLACEMENT ORIFICES			
DRILL SIZE	PART NUMBER	DRILL SIZE	PART NUMBER
44	ORF00501	54	ORF00555
45	ORF00644	55	ORF00693
46	ORF00909	56	ORF00907
47	ORF00910	57	ORF00908
48	ORF01099	58	ORF01338
49	ORF00503	59	ORF01339
50	ORF00493		

TABLE 12

GAS FLOW IN CUBIC FEET PER HOUR							
2 CUBIC FOOT DIAL							
SEC.	FLOW	SEC.	FLOW	SEC.	FLOW	SEC.	FLOW
8	900	29	248	50	144	82	88
9	800	30	240	51	141	84	86
10	720	31	232	52	138	86	84
11	655	32	225	53	136	88	82
12	600	33	218	54	133	90	80
13	555	34	212	55	131	92	78
14	514	35	206	56	129	94	76
15	480	36	200	57	126	96	75
16	450	37	195	58	124	98	73
17	424	38	189	59	122	100	72
18	400	39	185	60	120	104	69
19	379	40	180	62	116	108	67
20	360	41	176	64	112	112	64
21	343	42	172	66	109	116	62
22	327	43	167	68	106	120	60
23	313	44	164	70	103	124	58
24	300	45	160	72	100	128	56
25	288	46	157	74	97	132	54
26	277	47	153	76	95	136	53
27	267	48	150	78	92	140	51
28	257	49	147	80	90	144	50

HIGH ALTITUDE DERATE

TABLE 13

Orifice Twist Drill Size If Installed At Sea Level	ALTITUDE ABOVE SEA LEVEL and Orifice Required At Other Elevations								
	2000	3000	4000	5000	6000	7000	8000	9000	10000
42	42	43	43	43	44	44	45	46	47
43	44	44	44	45	45	46	47	47	48
44	45	45	45	46	47	47	48	48	50
45	46	47	47	47	48	48	49	49	50
46	47	47	47	48	48	49	49	50	51
47	48	48	49	49	49	50	50	51	52
54	54	55	55	55	55	55	56	56	56
55	55	55	55	56	56	56	56	56	57
56	56	56	57	57	57	58	59	59	60
57	58	59	59	60	60	61	62	63	63
58	59	60	60	61	62	62	63	63	64

From National Fuel Gas Code - Table F-4

installed altitude. Input rate changes can be made by adjusting the manifold pressure (min 3.0 - max 3.7 in. W.C. - Natural Gas) or changing orifices (orifice change may not always be required). Installation of this furnace at altitudes above 2,000 ft. (610m) must be in accordance with local codes, or in the absence of local codes, the National Fuel Gas Code, ANSI Z223.1/ NFPA 54 or National Standard of Canada, Natural Gas and Propane Installation Code, CSA B149.1, and must be made in accordance with the listed high Altitude Conversion Kit available with this furnace.

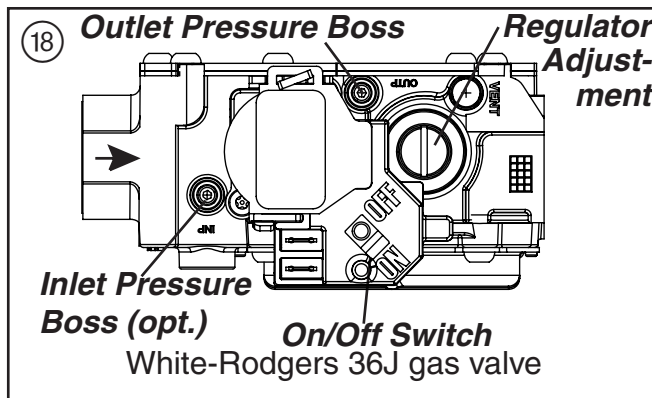

Table 14

FINAL MANIFOLD PRESSURE SETTINGS (inches w.c.)	
FUEL	PRESSURE
NATURAL GAS	3.5" W.C.
LP GAS	10.5" W.C.

If the desired input rate cannot be achieved with a change in manifold pressure, then the orifices must be changed. LP installations will require an orifice change.

⚠ WARNING

DO NOT attempt to manually light the burner. Failure to follow this warning could result in property damage, personal injury or death.

IMPORTANT: Re-install the propane orifices to the same depth as the orifices supplied with the equipment.

See Table 13 for help in selecting orifices if orifice change is required. Furnace input rate and temperature rise should be checked again after changing orifices to confirm the proper rate for the altitude.

Installations above 4,000 feet may require a pressure switch change. If required, use the BAYHALT*** Kit (High Altitude Accessory Kit) listed in PRODUCT DATA.

LIGHTING INSTRUCTIONS

Lighting instructions appear on each unit. Each installation must be checked out at the time of initial start up to insure proper operation of all components. Check out should include putting the unit through one complete cycle as outlined below.

Turn on the main electrical supply and set the thermostat above the indicated temperature. The ignitor will automatically heat, then the gas valve is energized to permit the flow of gas to the burners. After ignition and flame is established, the flame control module monitors the flame and supplies power to the gas valve until the thermostat is satisfied.

To shut off

For complete shutdown: Move the control switch on the main gas valve to the "OFF" position (See Figures 18). Disconnect the electrical supply to the unit.

⚠ CAUTION

If this is done during the cold weather months, provisions must be taken to prevent freeze-up of all water pipes and water receptacles.

Whenever your house is to be vacant, arrange to have someone inspect your house for proper temperature. This is very important in below freezing weather. If for any reason your furnace should fail to operate damage could result, such as frozen water pipes.

CONTROL AND SAFETY SWITCH ADJUSTMENT

LIMIT SWITCH CHECK OUT

The limit switch is a safety device designed to close the gas valve should the furnace become overheated. Since proper operation of this switch is important to the safety of the unit, it must be checked out on initial start up by the installer.

To check for proper operation of the limit switches, set the thermostat to a temperature higher than the indicated temperature to bring on the gas valve. Restrict the airflow by blocking the return air or by disconnecting the blower. When the furnace reaches the maximum outlet temperature as shown on the rating plate, the burners must shut off. If they do not shut off after a reasonable time and overheating is evident, a faulty limit switch is probable and the limit switch must be replaced. After checking the operation of the limit control, be sure to remove the paper or cardboard from the return air inlet, or reconnect the blower.

AIRFLOW ADJUSTMENT

Check inlet and outlet air temperatures to make sure they are within the ranges specified on the furnace rating nameplate. If the airflow needs to be increased or decreased, see the wiring diagram for information on changing the speed of the blower motor.

⚠ WARNING

Disconnect power to the unit before removing the blower door. Failure to follow this warning could result in property damage, personal injury or death.

This unit is equipped with a blower door switch which cuts power to the blower and gas valve causing shutdown when the door is removed. Operation with the door removed or ajar can permit the escape of dangerous fumes. All panels must be securely closed at all times for safe operation of the furnace.

NOTE: Direct drive motors have bearings which are permanently lubricated and under normal use, lubrication is not recommended

INDOOR BLOWER TIMING

The control module controls the indoor blower. The blower starts approximately 45 seconds after ignition. The FAN-OFF period is approximately 100 seconds from the interruption of gas flow.

ROOM AIR THERMOSTAT HEAT ANTICIPATOR ADJUSTMENT

Set the thermostat heat anticipator according to the current flow measured, or the settings found in the notes on the furnace wiring diagram (found inside the furnace casing).

INSTRUCTIONS TO THE OWNERS

In the event that electrical, fuel, or mechanical failures occur, the owner should immediately turn the gas supply off at the manual gas valve, located in the burner compartment (See Figure 17). Also turn off electrical power to the furnace and contact the service agency designated by your dealer.

⚠ WARNING

Should overheating occur, or the gas supply fail to shut off, shut off the gas valve to the unit before shutting off the electrical supply. Failure to follow this warning could result in property damage, personal injury, or death.

OPERATING INFORMATION

FLAME ROLL-OUT DEVICE

All models are equipped with a thermal control device on the burner cover. In case of flame roll-out, the device will cause the circuit to open which shuts off all flow of gas.

Abnormal Conditions

1. EXCESSIVE COMBUSTION VENT PRESSURE OR FLUE BLOCKAGE
If pressure against the induced draft blower outlet becomes excessive, the pressure switch will shut off the gas valve until acceptable combustion pressure is again available.
2. LOSS OF FLAME OR GAS SUPPLY FAILURE
If loss of flame occurs during a heating cycle (when flame is not present at the sensor), the control module will retry the

ignition sequence up to two times after the sensor cools. If ignition is not achieved, it will lockout the furnace.

3. POWER FAILURE

If there is a power failure during a heating cycle, the system will restart the ignition sequence automatically when power is restored, if the thermostat still calls for heat.

4. INDUCED DRAFT BLOWER FAILURE

If pressure is not sensed by the pressure switch, it will not allow the gas valve to open, therefore the unit will not start. If failure occurs during a running cycle, the pressure switch will cause the gas valve to close and shut the unit down.

⚠ WARNING

Failure to follow safety warnings exactly, could result in a fire or explosion causing property damage, personal injury or loss of life.

— **Do not store or use gasoline or other flammable vapors and liquids in the vicinity of this or any other appliance.**

— **WHAT TO DO IF YOU SMELL GAS**

- **Do not try to light any appliance.**
- **Do not touch any electrical switch; do not use any phone in your building.**
- **Immediately call your gas supplier from a neighbor's phone. Follow the gas supplier's instructions.**
- **If you cannot reach your gas supplier, call the fire department.**

— **Installation and service must be performed by a qualified installer, service agency or the gas supplier.**

The following warning complies with State of California law, Proposition 65.

⚠ WARNING

This product contains fiberglass wool insulation! Fiberglass dust and ceramic fibers are believed by the State of California to cause cancer through inhalation. Glasswool fibers may also cause respiratory, skin, or eye irritation.

PRECAUTIONARY MEASURES

- **Avoid breathing fiberglass dust.**
- **Use a NIOSH approved dust/mist respirator.**
- **Avoid contact with the skin or eyes. Wear long-sleeved, loose-fitting clothing, gloves, and eye protection.**
- **Wash clothes separately from other clothing: rinse washer thoroughly.**
- **Operations such as sawing, blowing, tear-out, and spraying may generate fiber concentrations requiring additional respiratory protection. Use the appropriate NIOSH approved respirator in these situations.**

FIRST AID MEASURES

- Eye Contact** – Flush eyes with water to remove dust. If symptoms persist, seek medical attention.
- Skin Contact** – Wash affected areas gently with soap and warm water after handling.

INTEGRATED FURNACE CONTROL ERROR FLASH CODES	
Flashing Slow ---	Normal - No call for Heat
Flashing Fast ---	Normal - Call for Heat
Continuous ON ---	Replace IFC
Continuous OFF ---	Check Power
2 Flashes ---	System Lockout (Retries or Recycles exceeded)
3 Flashes ---	Draft Pressure Error - Possible problems: a) Venting problem b) Pressure switch problem c) Inducer problem
4 Flashes ---	Open Temperature Limit Circuit
5 Flashes ---	Flame sensed when no flame should be present
6 Flashes ---	115 volt AC power reversed, poor grounding or system voltage too low
7 Flashes ---	Gas valve circuit error
8 Flashes ---	Low flame sense signal
9 Flashes ---	Igniter relay fault

Ingersoll Rand
800-E Beaty Street
Davidson, NC 28036

The manufacturer has a policy of continuous product and product data improvement and it reserves the right to change design and specifications without notice.